

We plan to work on the following research and development in three year plan.

### 1. Small lot electric power supply system

As for this system, the site test is scheduled to be done in patent fillings in India or Indonesia after the performance of experimental the first machine is evaluated now.

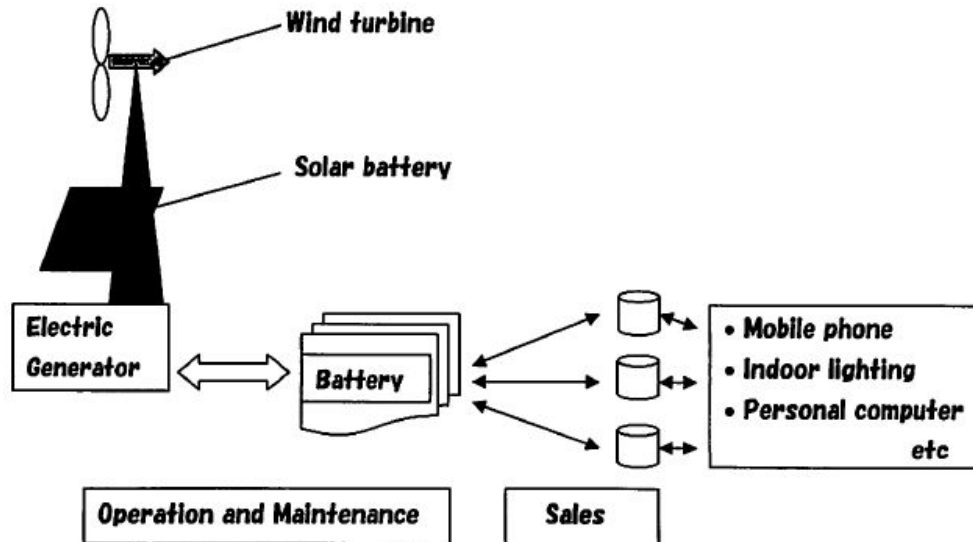
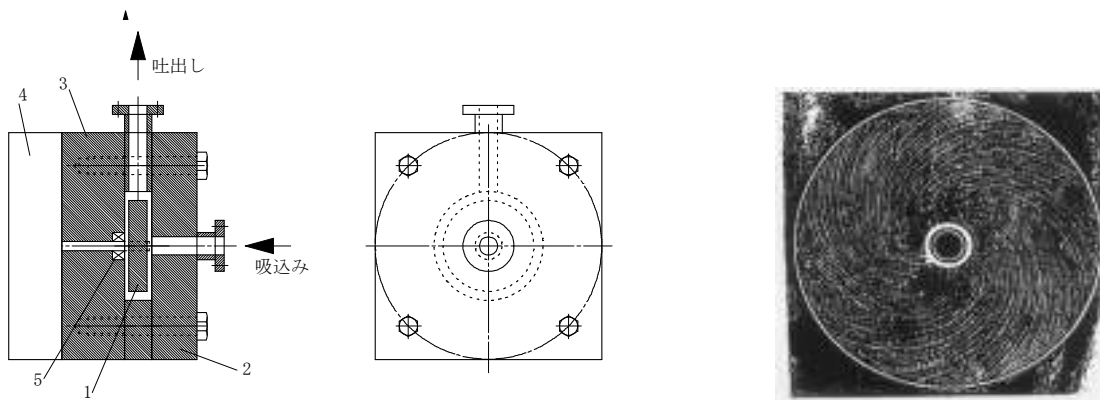

Figure 1 Small lot electric power supply system

### 2. Disk with fine groove type micro pump

This pump is used as pumps of the cooling systems of various electronic equipments.



(a) Cross section diagram

(b) Rotating disk surface

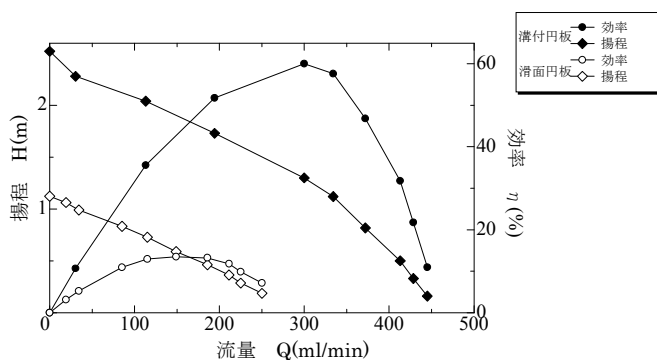

(c) Performance curve

Figure 2 Disk friction micro pump